

ASSAULT AIR BIKE

OWNER'S MANUAL

TABLE OF CONTENTS

SAFETY INSTRUCTIONS & WARNINGS	5
CARTON CONTENTS	6
ASSEMBLY STEPS	7
WORKOUT GUIDELINES	10
WORKOUT QUALITY AND QUANTITY	10
ASSAULT CONSOLE OVERVIEW	11
CONSOLE KEYS	13
CONSOLE SETUP	14
PROGRAMMING FEATURES	14
PROGRAM OPERATION	15
HEART RATE TRAINING	17
ASSAULT AIRBIKE LIMITED WARRANTY	19
MAINTENANCE	20
WARRANTY REGISTRATION CARD	21
PURCHASER'S REFERENCE INFORMATION	23

AssaultAirBike

2575 Pioneer Avenue, Suite 101 • Vista, CA 92081 • Phone 1 (888) 815-5559

For more information or questions regarding your equipment, please visit our website at AssaultAirBike.com

SAFETY INSTRUCTIONS & WARNINGS

Every Assault AirBike is built for maximum safety and meets or exceeds all applicable domestic and international standards. However, certain precautions must be taken when operating any piece of fitness equipment.

NOTE: *Please read the entire owner's manual before operating the unit. Save this manual for future reference.*

Assembly of Technical Items

Assembly of the Assault AirBike should be performed by a qualified technician. A significant amount of technical knowledge is required for the safe and complete assembly of the unit. Many retailers will offer delivery and assembly as part of the sales agreement. If this unit was sold unassembled (in the carton) and you do not feel you can perform the assembly successfully, please call the dealer for service. Service calls for improper assembly are not covered by the Warranty Policy and any associated charges will be the responsibility of the owner.

Warnings – To Reduce the Risk of Injury to Yourself and Others

- To ensure proper functioning of your unit, do not install attachments or accessories not provided with the Assault AirBike.
- Always wear proper clothing and shoes when exercising.
- User weight is not to exceed 330 pounds (147.4 Kg) for this unit.
- Keep children away from the unit. Hands and feet may become entangled with the moving parts and cause serious injury.
- Place the unit in an area that will meet minimum clearance requirements. Sides – 24 inches, front & rear – 12 inches.
- The unit is intended for indoor use only.
- Place the unit on a solid, level surface. Always adjust the leveling feet before using the AirBike.
- Ensure all adjustment knobs and levers are fastened securely before using the unit and after making an adjustment.
- The unit is heavy. Do not attempt to move alone.
- Never operate the unit if it is damaged or broken. Contact your local authorized Fitness Dealer for service.
- Do not remove the covers or other components. Only Authorized Fitness Dealers or Authorized Technicians should perform service on the unit.

Cautions – For Safe Operation

- If you have a history of heart disease, high blood pressure, diabetes, chronic respiratory diseases, elevated cholesterol, or if you smoke cigarettes or experience any other chronic diseases or physical complaints, consult with a physician before beginning any exercise program.
- If you are overweight or above the age of 55, consult with your physician before beginning an exercise program.
- Pregnant women should consult with their physician before beginning an exercise program.

CARTON CONTENTS

AS SHIPPED

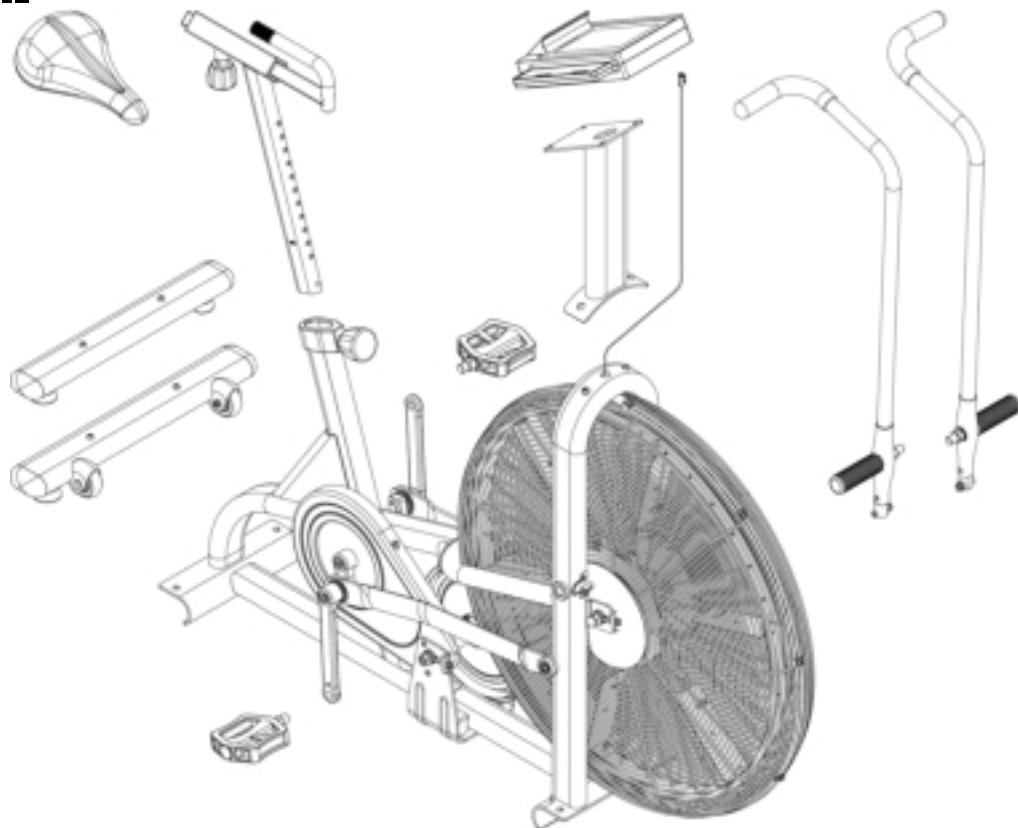

58 M8 x 20 Screw

34 M8 Lock Washer

35 M8 Flat Washer

85 M8 Nylock Nut

84 M8 Spacer

37 Pivot



M13/M17/M22
Wrench-Screwdriver



102 M6 Hex Wrench

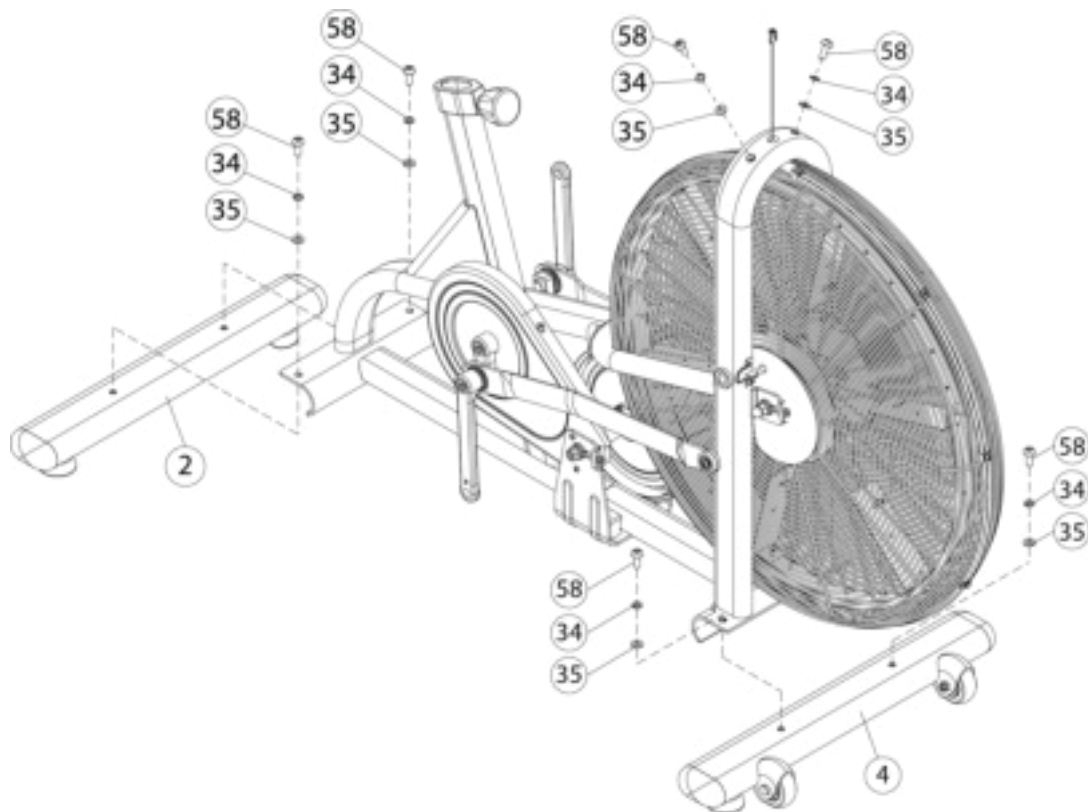

ASSEMBLY STEPS

1. Remove the pre-installed six (6) sets of M8 screw (58), lock washer (34) and flat washer (35) assemblies from the front stabilizer (1), rear stabilizer (2) & top arch of the main frame and set aside.
2. Align the front stabilizer (1) with the receiver on the main frame, and re-install the two screw, lock washer and flat washer assemblies (58, 34 & 35) with the supplied 6mm hex wrench (part #102).
3. Repeat step 2 for the rear stabilizer (4).

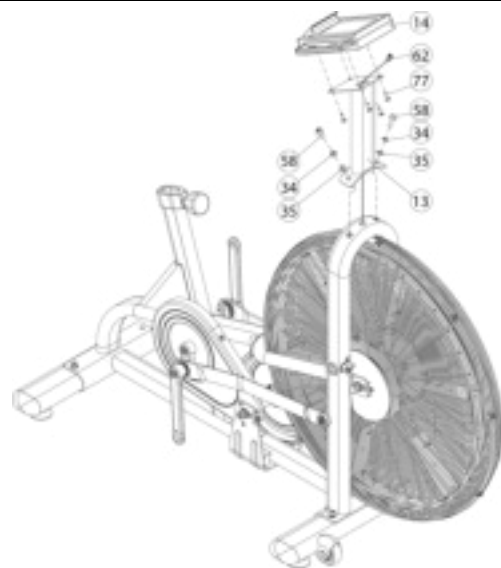

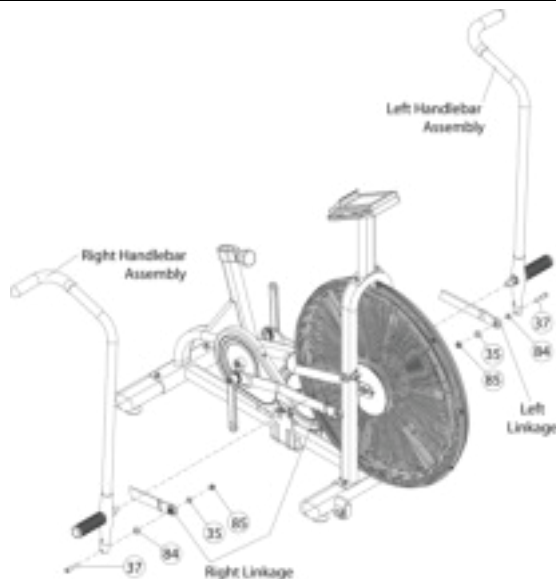

4. Inspect the console cable (62) for damage before threading it through the console mast (13).
5. Install the button head screw, lock washer and flat washer assemblies (58, 34 & 35) through the base of the console mast (13) and into the main frame.
6. Plug the console wire (62) into the backside of the console (14).
7. Insert the four screws (77) through the console mast (13) and into the back of the console (14).



8. Reinstall the two (2) pivot pin (37), spacer (84), flat washer (35) & locknut (85) assemblies from the Left & Right Handlebar Assemblies.
9. Install the left handlebar assembly by threading the backside of the foot peg assembly into the main frame. Tighten firmly with the M 12/M11/M22 wrench.
10. Insert the lower handlebar pivot (37) through the lower pivot of the left handlebar assembly.
11. Slide one flat washer (35), followed by the loose end of the left linkage arm, and one spacer (84) onto the the pivot (37). Tighten the assembly with the lock nut (85).
12. Repeat steps 7 through 9 for the right side.

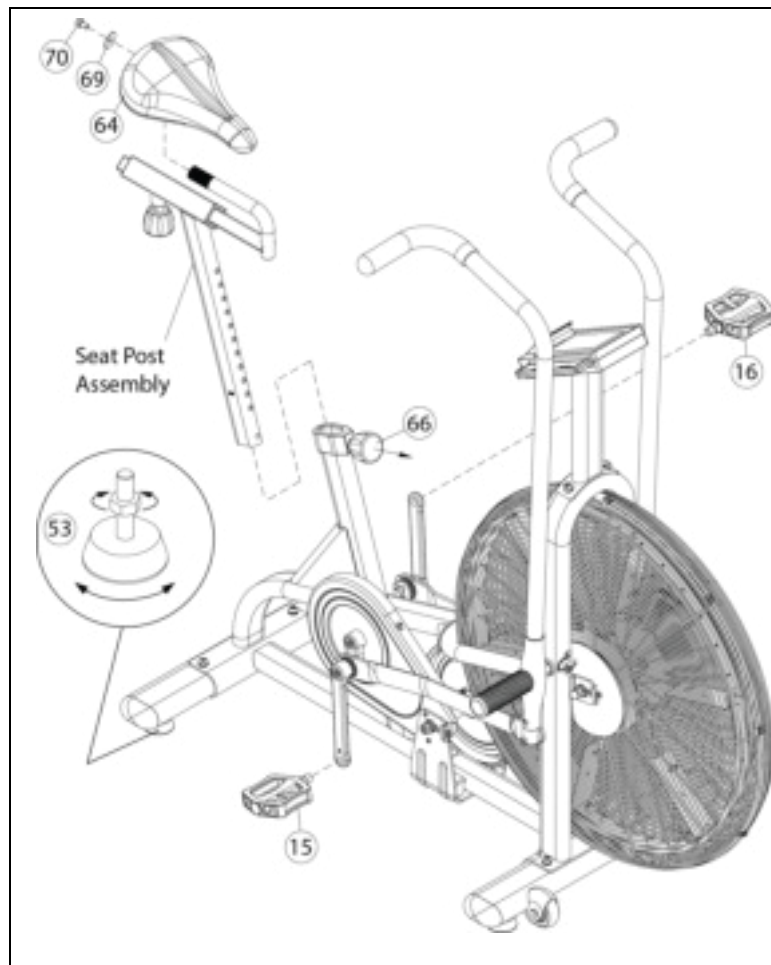

15. Loosen the seat clamp assembly that orients along the rails of the seat (64) and slip the assembly onto the knurled portion of the seat slide (63). Position the seat so that it is level with the ground, and fix clamp firmly.
16. Slide the flat washer (68) onto the hex screw (70) and thread the screw into the end of the seat slide assembly (5). Tighten firmly.
15. Loosen the pop pin (66) by grasping the knob and rotating counter-clockwise. Pull the pop pin outward, insert the seat post assembly into the frame, and release the pop pin when the seat is at the desired height. To ensure the pop pin is fully engaged, lift upward on the seat post assembly. Tighten the pop pin to secure it.
16. Loosely thread the left pedal (16) into the left crank arm by hand. The threads are reversed, rotate the axle counter-clockwise when viewed from the outward end of the pedal to install. Use the provided M13/M15 wrench to firmly fix the pedal. Repeat this process for the right pedal (15). Please note that right pedal axle will be rotated clockwise to install.
17. Level the unit by adjusting the four leveling feet (52). The feet may come from the factory tightened in the lowest position. Place a wrench on the nut and rotate clockwise if viewed from above to loosen. Adjust the foot to the desired height and tighten the lock nut against the underside of the stabilizer to lock in place.

WORKOUT GUIDELINES

Good Health is an Exercise in Common Sense

In the study titled, "The Surgeon General's Call-To-Action to Prevent and Decrease Overweight and Obesity", the surgeon general indicates that 61% of American adults are either overweight or obese. The study indicates that being overweight increases the risk of health problems, such as heart disease, certain types of cancer, as well as Type-2 diabetes among other afflictions.

WORKOUT QUALITY AND QUANTITY

It is recommended that you accumulate at least thirty (30) minutes of physical activity most days of the week. The American College of Sports Medicine makes the following recommendations for the quantity and quality of training for developing and maintaining cardio-respiratory fitness in healthy adults:

- An activity that uses large muscle groups, maintained continuously, and a rhythmical and aerobic in nature.
- Duration: 20 to 60 minutes of continuous aerobic activity, including a warm-up and cool-down period for each session.
- Frequency: 3 to 5 times per week.
- Intensity: 65% to 92% of maximum heart rate.

In addition to aerobic exercise, strength training of moderate intensity twice per week is recommended. Women especially may benefit from weight-bearing exercises. Select activities you enjoy and can fit into daily life.

Get a Smart Start on Exercising

Anyone over the age of 35, as well as younger persons whom are overweight, should check with his/her physician before commencing an exercise program. Persons who have diabetes or high blood pressure, a family history of heart disease, high cholesterol or have led sedentary lifestyles should protect themselves with a medical check-up and stress test administered by a healthcare professional.

- Stretching and massaging major muscles (such as your quadriceps) following a workout session will aid in the dissipation of lactic acid and speed your body's recovery.
- The first few minutes of your workout should be devoted to warming up the muscles before a vigorous workout. Concentrate on raising your heart rate slowly.
- After an aerobic workout of roughly 20-30 minutes, spend 10 minutes gradually reducing your heart rate by moving slower or with less resistance.

NOTE: *Start slow, with intensity low until you build up endurance and strength. Always consult your physician before beginning any exercise program.*

ASSAULT CONSOLE OVERVIEW

Console Layout

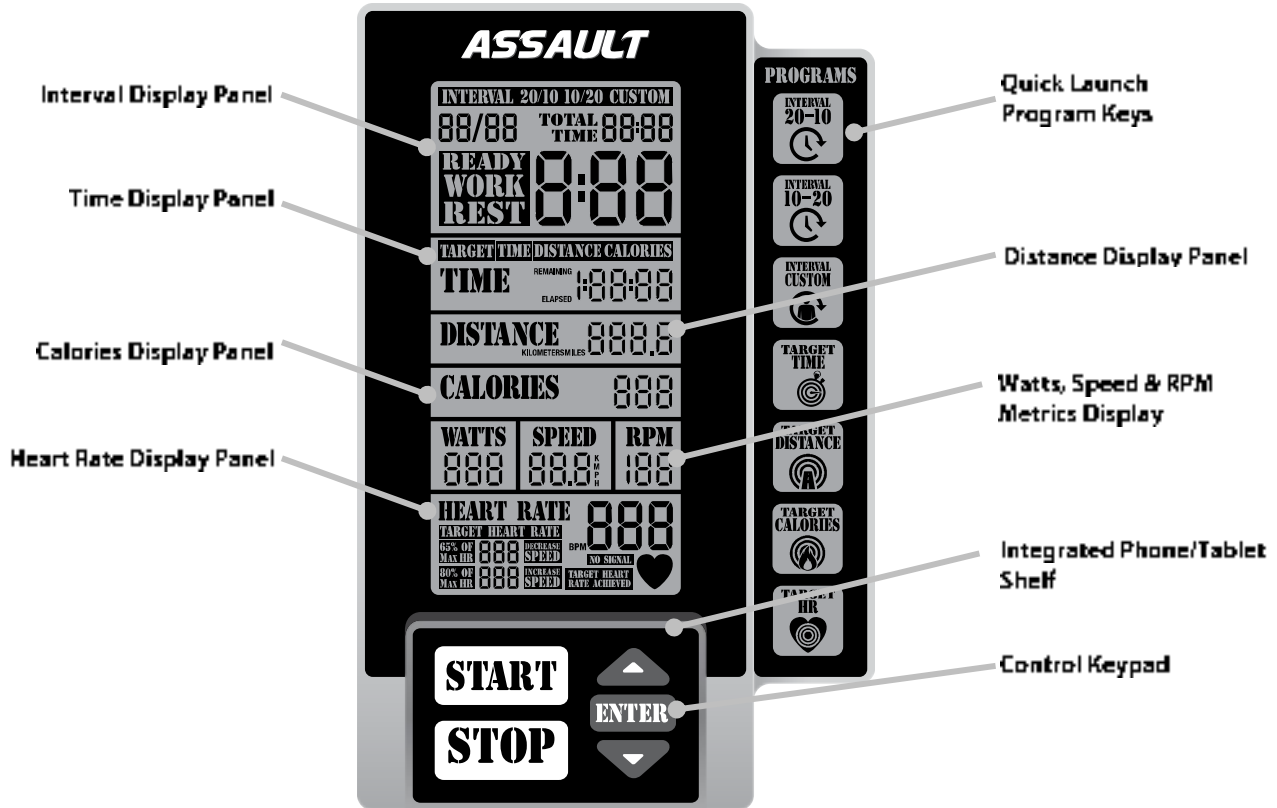

Interval Display Panel

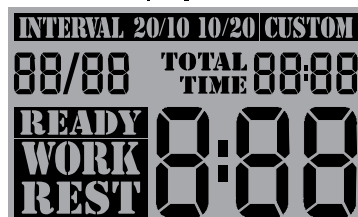

The Interval Display Panel will provide all display details for the Interval 20/10, Interval 10/20 and Interval Custom programs.

The upper banner will signal which interval program is running. This display will communicate whether the currently running interval is a Work or Rest period.

The Total Time display will count up the total program run time while the large numeric display will count up the Work or Rest segment time.

The 88/88 Display will show the current interval and the total number of intervals in the program.

Target Time, Distance & Calories Display Panel



The Target Display Panel will track Time, Distance and Calories during all programs.

A banner across the top will signify if one of the three Target programs is running.

The Time display will alternate between the remaining and elapsed values throughout the program.

Total distance will be displayed in miles or kilometers depending upon how the console was programmed during the initial setup.

The Calories display field will track the number of calories burned during the workout.

Watts / Speed / RPM Display



Watts, Speed and RPM will be displayed during all programs.

Watts are a measurement of energy generation and are frequently used to track the amount of work generated at any given time during a workout.

The Speed display will post a value which simulates that of riding a standard bicycle and is derivative of the current RPM or pedal speed. The value will be given in miles-per-hour or kilometers-per-hour, depending upon which units were selected during the console setup process. RPM or revolutions-per-minute relates to the speed at which the cranks are spinning.

Heart Rate Display Panel



This panel will post a variety of information relating the user's heart rate.

When a signal is detected by the wireless monitor, the user's heart rate will be displayed in the large, three-digit BPM (beats-per-minute) field and the Heart icon will flash. Conversely, when a signal is not detected, the No Signal banner will post and the Heart icon will not light.

When the target heart rate program is running, the console helps the user maintain a BPM range to build cardio-vascular endurance. The upper and lower values of the target range will post next to the 65% of Max HR and 80% of Max HR banners and the Decrease Speed or Increase Speed banners will flash to signal that an increased or decreased pedal speed is needed to bring the heart rate into the desired range. When the user's heart rate is within the target range, the Target Heart Rate Achieved banner will post.

CONSOLE KEYS

START Key



The START key will launch a program and restart a paused program.

STOP Key



Use the STOP key to end a program or temporarily pause a running program.

ENTER Key



The ENTER key is used to confirm a value to be entered while making adjustments to a program.

UP/DOWN Arrow Keys



The UP/DOWN Arrow keys allow the user to increase and decrease console values.

Program Quick Keys



The Program Quick Keys will launch the associated programs immediately.

CONSOLE SETUP

Battery Installation

The Assault AirBike console operates on two (2) AA batteries (not included). The battery compartment is on the back side of the console.

Metric & Standard Units – Setup Mode

The Assault AirBike is shipped from the manufacturing facility with the distance units set to miles. The distance and speed will be calculated and displayed in miles and miles-per-hour.

To toggle the console display units between miles to kilometers, press and hold the START and ENTER keys simultaneously for two (2) seconds while the console is in the Ready Mode. The Setup Mode will launch and the "Distance" banner will be displayed on the LCD screen. Either "kilometers" or "miles" will flash to indicate the current setting. Press the UP or DOWN arrow key to toggle between the two settings. Press the ENTER key to accept the displayed option and launch the Ready Mode.

PROGRAMMING FEATURES

Sleep Mode

After five (5) minutes of inactivity, the console will enter the power-saving Sleep Mode. The display will switch off, but all previously entered data will be saved. To launch the Ready Mode, rotate the pedals or press any button on the console.

Ready Mode

The Ready Mode is designed to notify the user that the console is powered on and ready to begin a program. The Ready Mode is five (5) minutes in length. If no other activity occurs before the Ready Mode period has elapsed, the console will re-enter the Sleep Mode.

Reset Process

To reset all saved settings (except the metric versus standard/English units setting), press and hold the STOP key for two seconds.

Pause Mode

While any program is running, pressing the START key will launch the Pause Mode for five (5) minutes. The onboard beeper will sound every thirty (30) seconds to serve as a reminder and the display will flash on and off. If no further input is made, the Pause Mode will end and the console will enter the Ready Mode. To exit the Pause Mode and continue the currently running program, press the START key. To quit the paused program at any time, press the STOP key to launch the Ready Mode.

Elapsed Time and Remaining Time Switching

While running a program, the Total Time and Segment Time values will switch between *elapsed* and *remaining*.

Program Quick Launch

The Assault AirBike console allows the user to change the program with the touch of a single key. At any time during the workout, press a Program Quick Key to launch the associated program immediately.

Workout Summary

For additional user feedback, the Assault AirBike console provides a brief Workout Summary immediately following the completion of the workout session. All metrics such as total time, total distance and total Watts will post for two (2) minutes.

PROGRAM OPERATION

Default Program (Quick Start)

The Quick Start program option is for users who wish to bypass the onboard programming and begin their workout immediately. The Quick Start program will launch as soon as the pedals begin to move. The console will begin to display all metrics, including the user's heart rate if a signal is detected. The program will run continuously until the pedals stop moving. To end the program and view the Workout Summary, press the STOP key.

INTERVAL 20/10 & INTERVAL 10/20 Programs

The Interval 20/10 and Interval 10/20 programs offer the user a series of eight (8) high-intensity workout intervals with preset time segments. This training protocol is commonly known as Tabata[®] or (High Intensity Interval Training (HIIT)). The program will automatically signal the start of each work and rest interval.

Interval 20/10 Program Number of Intervals: 8 Work Interval Length: 20 seconds Rest Interval Length: 10 seconds	Interval 10/20 Program Number of Intervals: 8 Work Interval Length: 10 seconds Rest Interval Length: 20 seconds
---	---

Launch: Press the Interval Custom program key.

Run: The time will count down from three to signal the start of each work interval.

End: The program will run until the last of the rest segments end. To end the program at any time, press the STOP key. The Workout Summary will launch and post a record of the workout data.

INTERVAL CUSTOM Program

The Interval Custom program is similar to the Interval 20/10 Program except the user has the ability to set the length of the work and rest intervals as well as the total number of intervals.

Launch: Press the Interval Custom program key.

Setup: When running the Interval Custom program for the first time (or after the console has been reset), the user will be required to enter the total number of intervals. Adjust the displayed value by pressing the UP or DOWN keys, followed by the ENTER key to confirm. The default work interval will then post. Adjust the display value with the UP or DOWN keys. Confirm by pressing ENTER. The default rest interval will post. Adjust the value and confirm by pressing ENTER.

Run: The time will count down from three to signal the start of each work interval and the program will run immediately.

End: The program will end automatically when all intervals segments have been run. To end the program at any time, press the STOP key. The Workout Summary will launch and post a record of the workout data.

TARGET TIME, TARGET DISTANCE and TARGET CALORIES Programs

The Target Time, Target Distance and Target Calories programs each operate in the identical manner. In each program, the user has the ability to define a set value and the program will continue until that goal has been achieved.

Launch: Press the desired Target program key.

Setup: When running the Target programs for the first time (or after the console has been reset), the display will flash with the default value. Adjust the displayed value by pressing the UP or DOWN keys, followed by the ENTER key to confirm. The program will begin automatically.

Run: The display fields will light and begin to track the progress of the user.

If the Target Time program has been selected, the time target will begin to count down.

If the Target Distance program is running, the console will track the progress toward that goal.

When the Target Calories program has been selected, console will track calories.

End: The program will end automatically when the selected target has been achieved. To end the program at any time, press the STOP key. The Workout Summary will launch and post a record of the workout data.

TARGET HEART RATE Program

The Assault AirBike Target Heart Rate Program offers users the ability to target a BPM (beats-per-minute range) for maximum cardiovascular training. With one piece of information (the user's age), the console will automatically calculate the Calculated Maximum Heart Rate as well as the optimized training range (65% of Max Bpm to 80% of Max Bpm).

Launch: Press the Target Heart Rate program key to launch the program.

Setup: When running the Target HR programs for the first time (or after the console has been reset), the ACE? Banner and default age value will flash. Adjust the user's age by pressing the UP or DOWN keys, followed by the ENTER key to confirm. The program will begin automatically.

Run: The display fields will light and begin to track the progress of the user.

If the user's heart rate is below the calculated 65% of max HR range, the SPEED UP banner will flash to indicate that more effort is required to maintain the optimal heart rate.

If the user's heart rate exceeds 80% of the calculated maximum heart rate, the SLOW DOWN banner will flash signaling that the user is working too hard.

End: The Target Heart Rate program will run continuously until ended manually by the user. To end the program at any time, press the STOP key. The Workout Summary will be displayed.

HEART RATE TRAINING

Heart Rate Is an Important Key to Your Exercise

The Surgeon General also released a report on physical activity and health. This report dictates that exercise and fitness are beneficial for a person's health and reiterated the need for exercise as a key component for disease prevention and healthier living.

The best way to determine exercise intensity is to monitor your pulse rate. Your heart rate can easily be determined by counting the number of heartbeats per minute at the chest, wrist or the carotid artery on your neck. It is difficult however to count your own pulse while exercising as it is not possible to count fast enough to accurately track the number of beats per minute. To aid in heart rate training, the Assault AirBike is equipped with a wireless heart rate receiver which can detect a HR signal being transmitted by a wireless chest strap (not included).

Using the Wireless Heart Rate Receiver

In general, a wireless heart rate chest strap (not included) is the most accurate and convenient method of detecting and monitoring a heart rate signal and is a considerable upgrade from the touch-type heart rate sensors. Occasionally, certain factors can negatively affect the accurate transmission of the heart rate signal. Wi-Fi networks, cordless telephones and large electrical appliances may degrade or corrupt the signal so that the rate appears erratic or impossibly high. The only remedy for such a symptom is to isolate the unit from potential disturbances. Additionally, a person's body chemistry or lack of perspiration can prevent the chest strap from providing a strong or accurate heart rate signal. A wireless telemetry heart rate receiving system is one feature found on this unit. In order for the console to detect and display your heart rate wirelessly, four (4) conditions must be present:

- A compatible heart rate chest strap transmitter must be functioning and worn. For proper function of the chest strap, please refer to the manufacturer's instructions. Non-coded transmitters such as the Polar model T31 and T31 are examples of wireless chest straps known to be compatible with this unit. Contact us to order a compatible heart rate transmitting chest strap.
- The unit must be powered on.
- A workout program must be running.
- The user is within three (3) feet of the console.

Calculated Maximum Heart Rate & Target Training Zone

Your target heart rate depends primarily upon your age. It is important to work within a safe and productive zone, for if the exercise intensity is too low or too high, only modest gains will be made in strength and cardiovascular fitness. A workout at a very low intensity will not offer maximum benefits. Conversely, if the workout intensity is too high, injury or fatigue may slow the progression of your exercise goals as the body attempts to recover.

Note: *It is generally perceived that it is most effective to train at a heart rate between 65% and 80% of your maximum heart rate. Maximum heart rate is calculated as a percentage of your maximum heart rate (estimated as 220 BPM minus your age).*

To calculate your maximum heart rate and find the appropriate target training zone, use the following formulas. The following estimation would be relevant for a 35-year-old user:

- $220 - 35 = 185$ BPM $220 - \text{Age} = \text{Calculated Maximum Heart Rate in BPM}$
- $0.65 \times 185 = 120$ BPM $65\% \text{ of } 185 \text{ BPM [Calculated Maximum Heart Rate]} = 120 \text{ BPM}$
- $0.80 \times 185 = 148$ BPM $80\% \text{ of } 185 \text{ BPM [Calculated Maximum Heart Rate]} = 148 \text{ BPM}$

Based on these calculations, the recommended heart rate training zone for this user would be between 120 BPM and 148 BPM. The graph to the left displays the recommended heart rate training zone for users twenty years of age to seventy-five years of age.

ASSAULT AIRBIKE LIMITED WARRANTY

Frame Parts – Five Year Limited Warranty

We will replace or repair, at our discretion, the frame parts listed below that fail due to a defect in material or workmanship for a period of five years from date of purchase of the Assault AirBike.

The warranty is extended to the individual whose name appears on the Warranty Registration and may not be transferred to any other individual or legal entity. In the absence of a valid Warranty Registration, the original sales receipt will serve as satisfactory documentation of the valid warranty status.

This warranty excludes damage to the finish of the machine, damage sustained as a result from neglect, abuse, or failure to follow the suggested maintenance requirements (see Maintenance), shipping charges and if applicable, labor for the installation of any parts shipped to the owner under this warranty.

The Five Year Warranty applies to the main frame, stabilizers, flywheels, flywheel cage, seatpost, seat saddle, handlebar, driveline, and console mast.

Other Parts – Two Year Limited Warranty

We will replace or repair, at our discretion, any part that fails for any reason for a period of two (2) years from date of purchase of your Assault AirBike.

The warranty is extended to the individual whose name appears on the Warranty Registration and may not be transferred to any other individual or legal entity. In the absence of a valid Warranty Registration, the original sales receipt will serve as satisfactory documentation of the valid warranty status.

This warranty excludes damage to the finish of the machine, damage sustained as a result from neglect, abuse, or failure to follow the suggested maintenance requirements (see Maintenance), shipping charges and if applicable, labor for the installation of any parts shipped to the owner under this warranty.

Additional Information

The provisions of this warranty are in lieu of any other warranty, whether express or implied, written or oral.

Under no circumstances shall we be liable to purchase or any other person for any special, incidental or consequential damages, whether arising out of breach of warranty or otherwise.

Some states/territories do not allow the exclusion or limitation of special, incidental or consequential damages, so the above limitation or exclusion may not apply to you. In the event of a defect, malfunction, or other failure of the product not caused by any misuse or damage to the product while in the possession of the consumer, we will remedy the failure or defect, without charge to the consumer, within 14 business days of its receipt of the product. The remedy will consist of repair or replacement of the product, or refund of the purchase price, at our discretion. However, we will not elect refund unless we are unable to provide replacement, and repair is not commercially practicable.

and cannot be made within the time for performance or, unless the consumer is willing to accept such refund, replacement of a component part includes its free installation if the unit is returned to us.

This warranty gives you specific legal rights, and you may also have other rights that vary from state to state/territory to territory. This warranty does not cover shipping charges or labor for installation of any parts shipped to you under warranty. The term of this warranty begins on the date the product is shipped to the purchaser, and continues for a period of two (2) years.

Voided Warranty

The warranty does not apply to any failure of the product or its components due to alterations or modifications, misuse and abuse, accidents, damage, lack of maintenance or improper assembly. Improper assembly can be avoided if the unit is assembled by an authorized technician. Damage due to improper assembly is not covered by the warranty. Common assembly errors can include damaged wire harnesses, stripped screws and nuts, crank arms or damaged threads. If the serial number has been removed, altered or defaced, the warranty for the affected unit is voided.

Warranty Registration

Warranty commitments are valid only with a completed Warranty Registration. Please return the warranty card (See page 23).

MAINTENANCE

All Assault AirBike models are engineered for years of operation. Let noise be your first indication that a repair or adjustment is required.

Please discontinue use immediately and contact an Authorized Service Technician or Fitness Dealer if an unusual noise, scraping, knocking, grinding or vibration is detected. Often, a minor issue will become a major repair if ignored and use is continued.

Prior to each workout, confirm that all adjustment levers and screws are tightened.

The Assault AirBike is manufactured of the most durable materials available. The plastics are molded of strong and chemical-resistant ABS and PVC. The frame is produced of high-tensile steel and protected with an industrial-grade, powder paint coating for the highest level of corrosion resistance. It is important to note however, that perspiration can be extremely corrosive if allowed to accumulate on the machine. After training, always wipe down the unit with a mild soap solution followed by a thorough drying with a clean towel. Positioning a small spray bottle and towel near the unit will help ensure that your equipment looks new for many years.

NOTE: *Perspiration is very corrosive and if allowed to remain on the machine, will cause discoloration, fading, rust and odors. Unfortunately, these conditions are not covered under the Warranty Policy.*

WARRANTY REGISTRATION

Please return the completed warranty registration card 15 days of purchase. Failure to comply may void the warranty.

Name (Last, First)

Address

City State/Province Zip/Country Code

Daytime telephone: () - Evening telephone: () -

Store Name

Store Address

City State/Province Zip/Country Code

Model **Assault AirBike** Serial Number: **A** ___ ___ **B B** ___ ___ Date of Purchase - -

Mail Completed Form To: Assault AirBike – Warranty Care 25/5 Pioneer Avenue, Suite 101 • Vista, CA 92081

PURCHASER'S REFERENCE INFORMATION

Product Name: ASSAULT AirBike

Serial Number: **A** _____ **BB** _____

Record the serial number here.

Serial Number Location

The serial number will be located on the left side of the unit. See the figure to the right.

Record of Purchase

NOTE: *Please record details associated with the purchase of your Assault AirBike below. This information will be required in the event the unit requires future service.*

ATTACH THE PURCHASE RECEIPT.

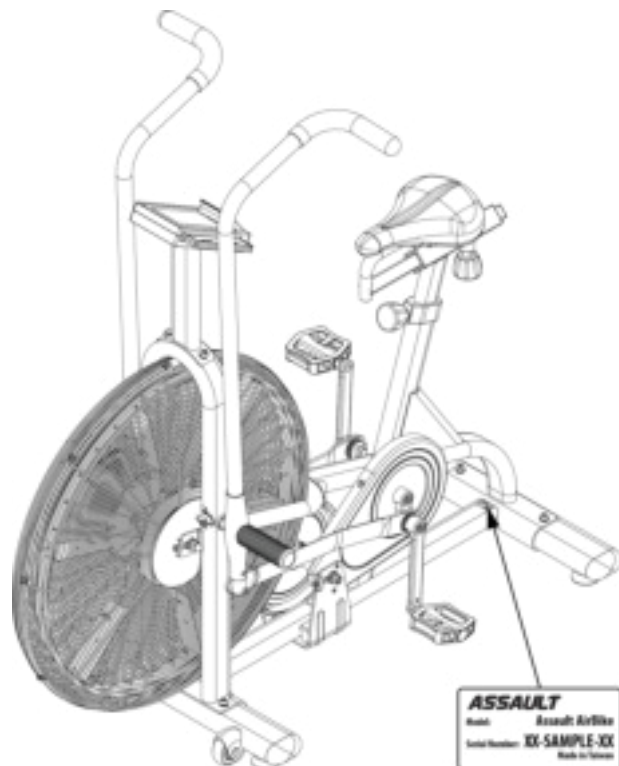

Dealer Name: _____ Dealer Telephone Number: (____) _____ - _____

Dealer Address: _____

Date Purchased: _____ Dealer Contact Name: _____